

外形尺寸图表 Outline dimensional

HRA200配750W伺服 HRA200 with 750W servo motor

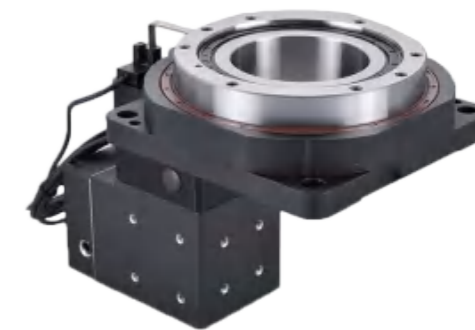
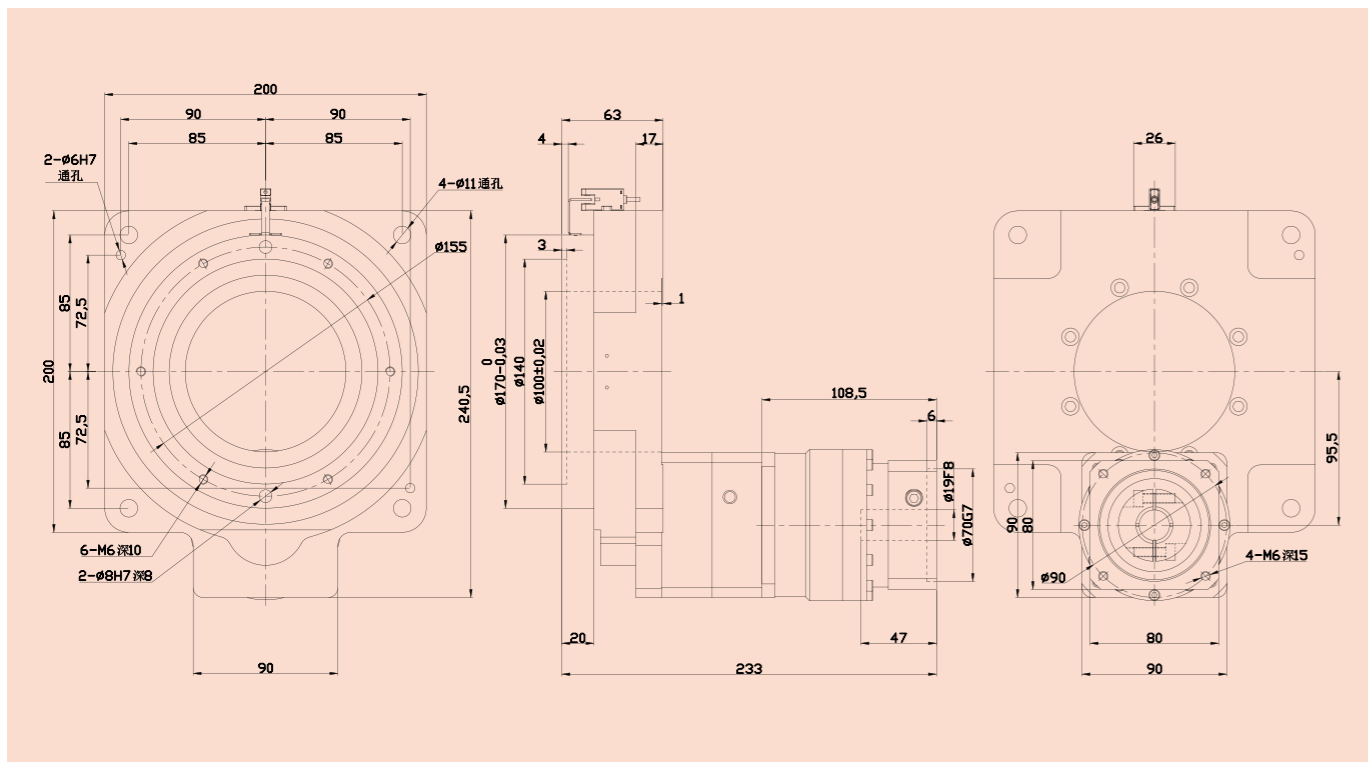

型号说明 MODEL ILLUMINATE

HRG	85	RL	10	8	30	45
系列 series	型号规格 Model Specifications	选配 Optional	速比 speed ratio	电机轴径 Motor shaft diameter	电机定位凸台 Motor positioning boss	电机安装孔距 Motor mounting hole distance
HRG HRA HRZ	85 130 200	RL:直角标准 RL: Right Angle Standard RY:直角右 RY: Right angle right RZ:直角左 RZ: Right Angle Left JS:同轴减速机 JS: Coaxial reducer	-05:10,15,25 -10:20,30,50			注:(伺服电机安装面对角孔距) (步进电机安装面单边孔距) Note: (The corner hole distance of the servo motor mounting face) (Single side hole spacing of stepper motor mounting surface)

技术参数 TECHNICAL PARAMETER

型号 Model	单位 Unit	HRZ85-05配57步进			HRZ85-05配400W伺服			HRZ85-10配57步进			HRZ85-10配400W伺服		
减速比 Ratio		10	15	25	10	15	25	20	30	50	20	30	50
额定输出扭矩 Rated torque	N·m	28	28	23	28	28	23	18	23	15	18	23	15
最大输出扭矩 Maximum torque		3倍额定输出扭矩3 times rated torque											
轴承结构 Bearing		交叉滚子轴承Cross roller bearing											
容许轴向负载 Allowable axial load	N	500											
容许惯性力矩 Allowable inertia torquel	N·m	10											
容许盘面转速 Allowable output speed		200rpm(间歇运转Indexing operation)											
旋转平台平行度 Outqut concentricity	mm	≤0.01											
旋转平台同心度 Overturning torque	mm	≤0.01											
齿隙 Backlash		无齿隙(可调节结构)Zero backlash (adjustable structure)											
扭转刚性 Torsional rigidity	N·m/arcmin	6											
精度寿命 Aocuracy life		30000h(间歇运转Indexing operation)											
定位精度 Positioning accuracy	arcmin	≤3											
反复定位精度 Repeatability	arcsec	≤30											
防护等级 Protection level		IP50											
适配电机接口 Adapter motor interface		400W伺服 (Ø14-Ø50-Ø70)											
光电开关 Sensor		标配 Free supply											
润滑方式 Lubrication method		长效润滑Long term lubrication											
传动效率 Efficiency		90%											
噪音 Noise	dB	63											
重量 Weight	kg	2.6											
安装方式 Installation method		任意Arbitrarilly											
设计承重 Design load	kg	20											

*以上技术参数仅供参考，实际根据客户提供的数据，会出具相关的技术参数及尺寸。

* The above technical parameters are for reference only. According to the data provided by the customer, the relevant technical parameters and dimensions will be issued.

外形尺寸图表 Outline dimensional

HRZ85-05配57步进 HRZ85-05 with 57 stepping motor

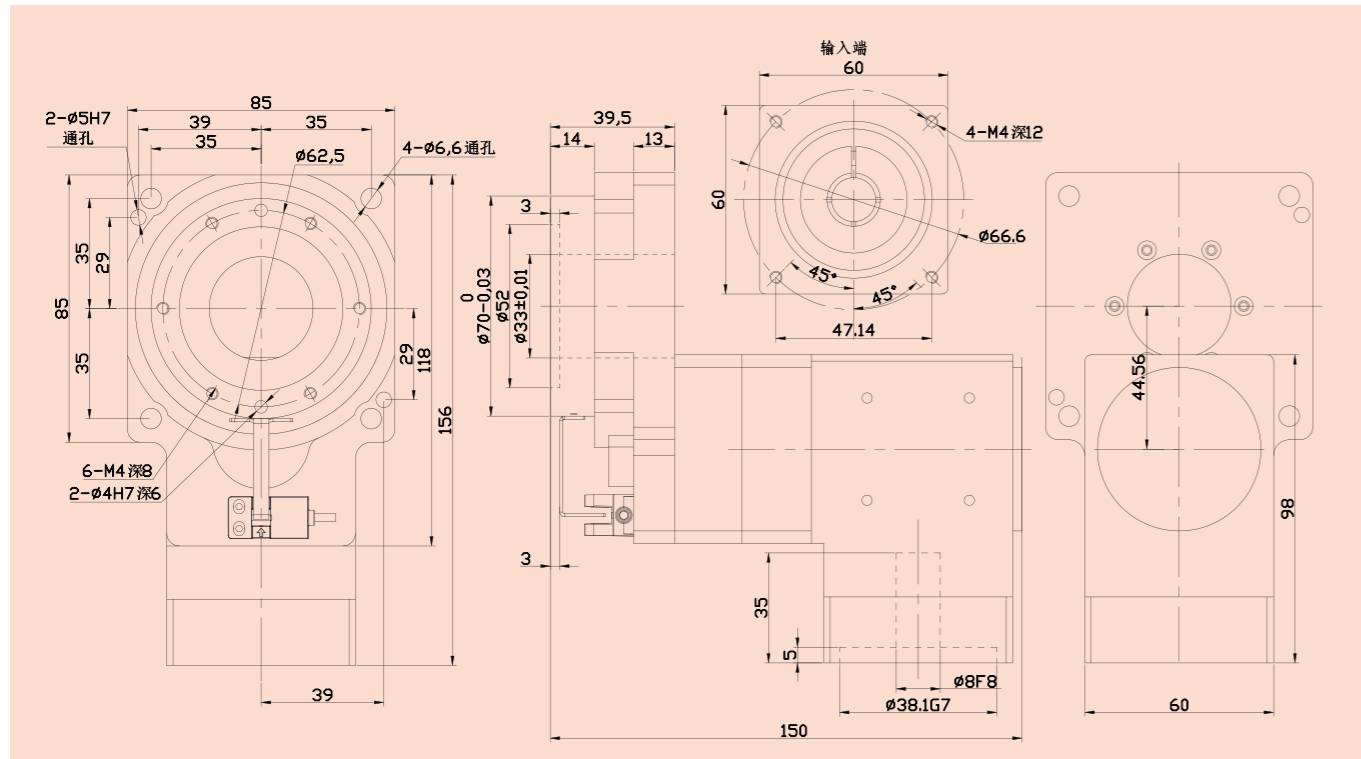

外形尺寸图表 Outline dimensional

HRZ85-10配57步进 HRZ85-10 with 57 stepping motor

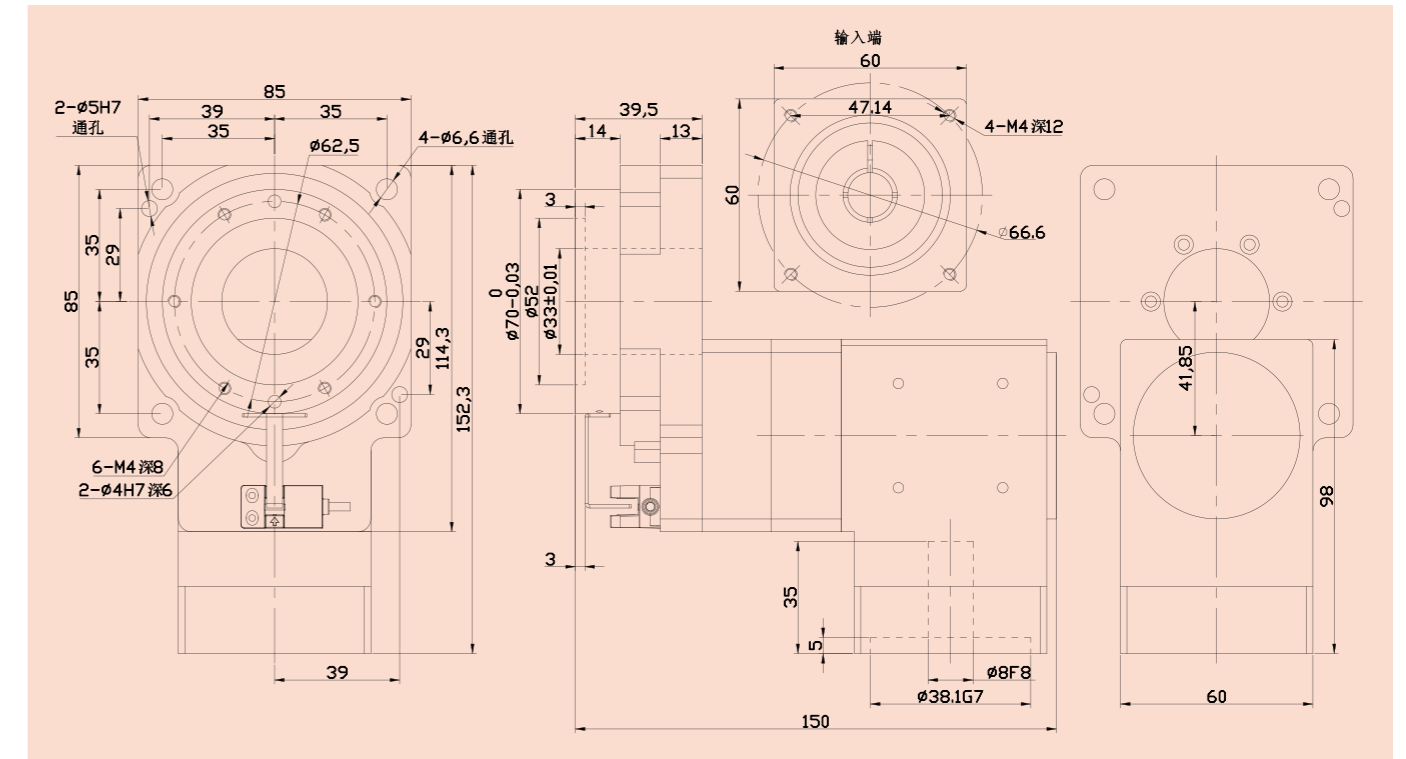

HRZ85-05配400W伺服 HRZ85-05 with 400W servo motor

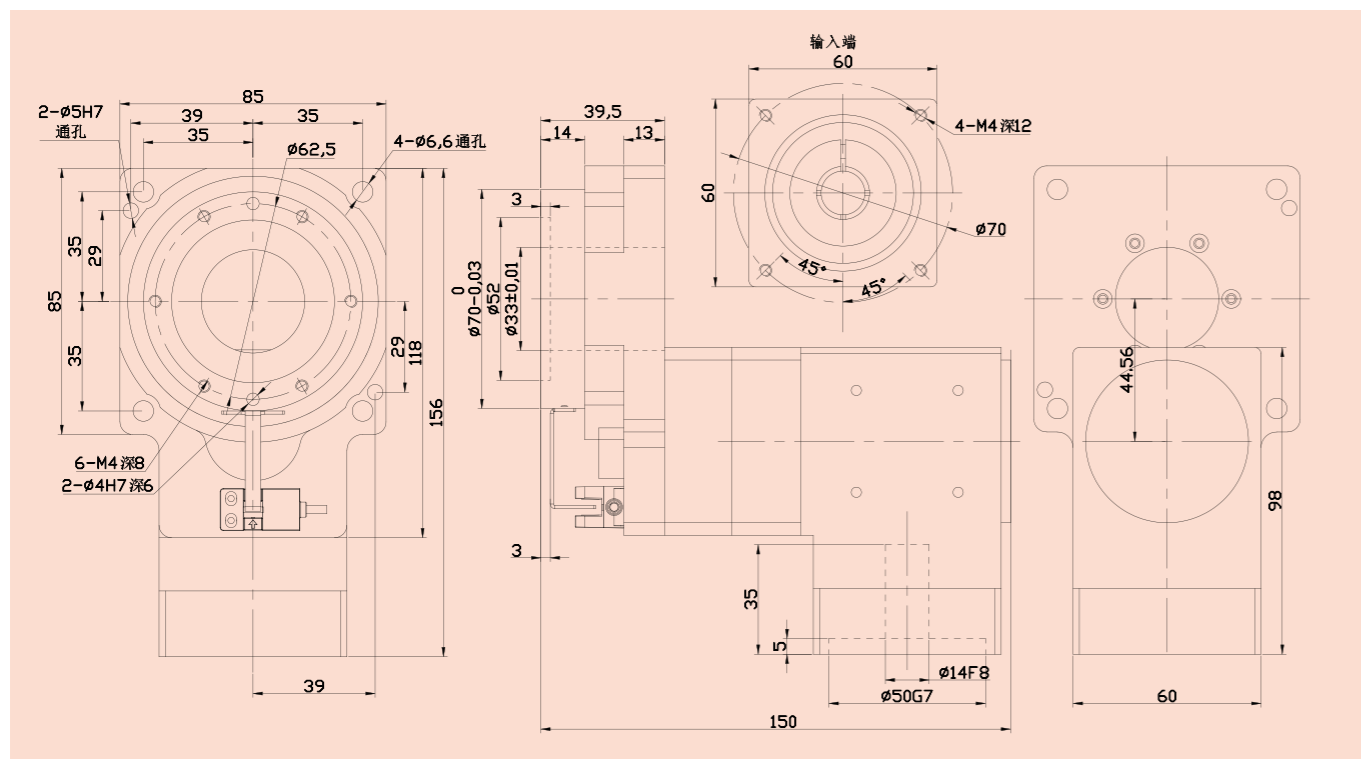

HRZ85-10配400W伺服 HRZ85-10 with 400W servo motor

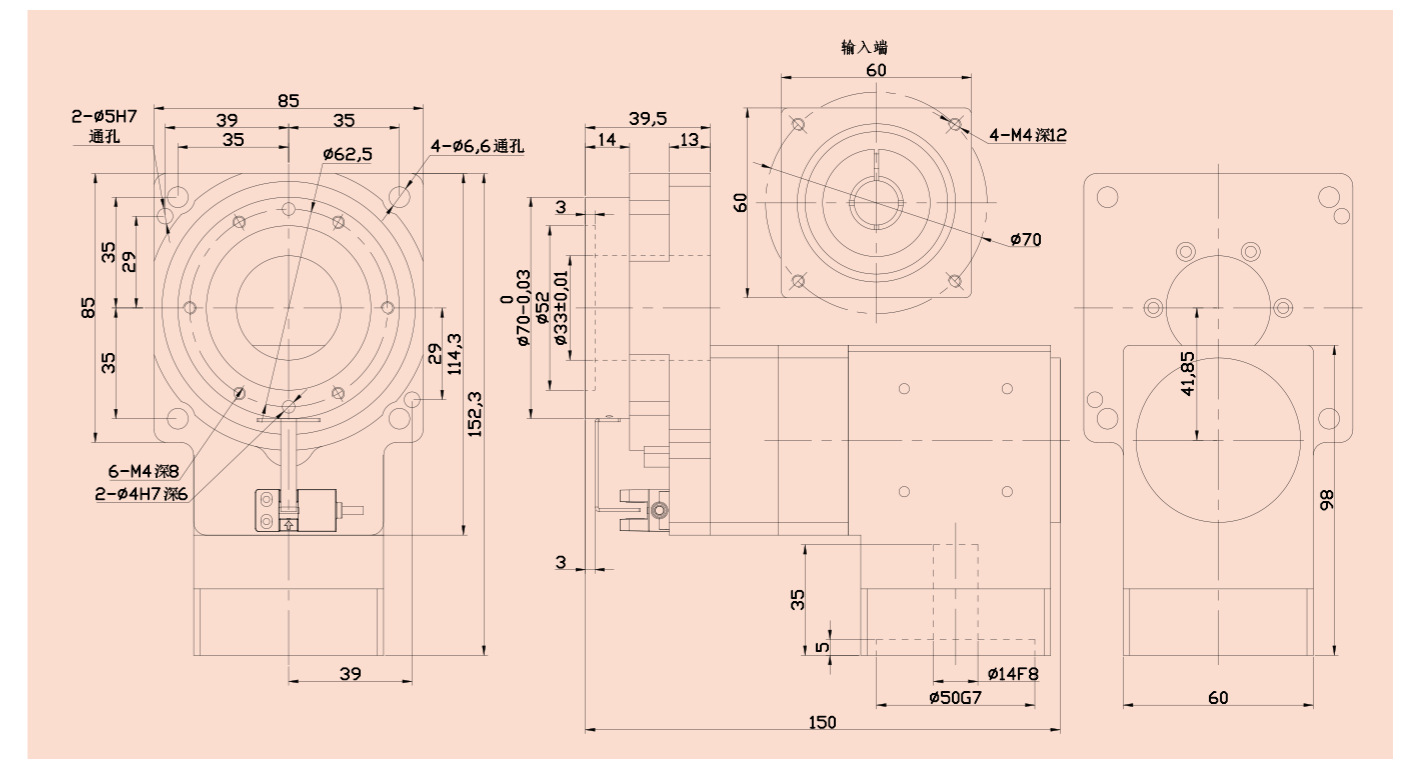

型号说明 MODEL ILLUMINATE

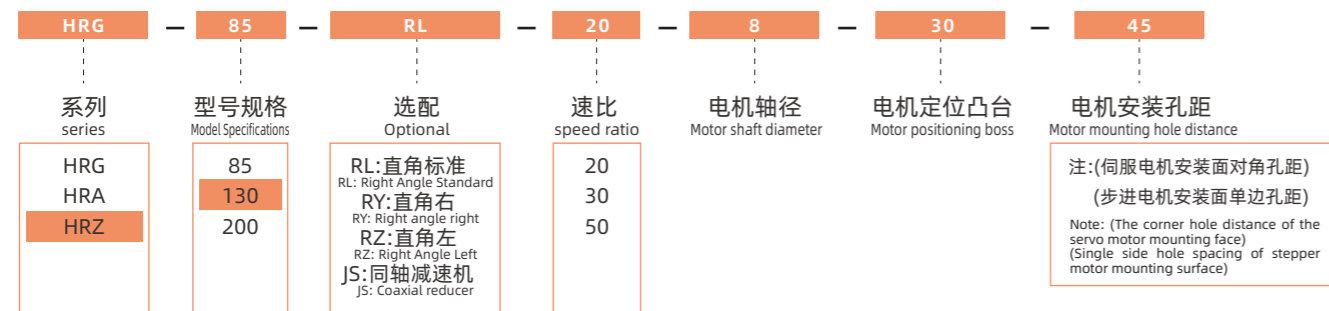

技术参数 TECHNICAL PARAMETER

型号 Model	单位 Unit	HRZ130配57步进			HRZ130配400W伺服		
减速比 Ratio		20	30	50	20	30	50
额定输出扭矩 Rated torque	N·m	40	40	35	40	40	35
最大输出扭矩 Maximum torque		3倍额定输出扭矩3 times rated torque					
轴承结构 Bearing		交叉滚子轴承Cross roller bearing					
容许轴向负载 Allowable axial load	N	2000					
容许惯性力矩 Allowable inertia torquel	N·m	50					
容许盘面转速 Allowable output speed		200rpm(间歇运转Indexing operation)					
旋转平台平行度 Outqut concentricity	mm	≤0.013					
旋转平台同心度 Overturning torque	mm	≤0.01					
齿隙 Backlash		无齿隙(可调节结构)Zero backlash (adjustable structure)					
扭转刚性 Torsional rigidity	N·m/arcmin	19					
精度寿命 Aocuracy life		30000h(间歇运转Indexing operation)					
定位精度 Positioning accuracy	arcmin	≤3					
反复定位精度 Repeatability	arcsec	≤30					
防护等级 Protection level		IP50					
适配电机接口 Adapter motor interface		400W伺服 (Ø14-Ø50-Ø70)					
光电开关 Sensor		标配 Free supply					
润滑方式 Lubrication method		长效润滑Long term lubrication					
传动效率 Efficiency		90%					
噪音 Noise	dB	60					
重量 Weight	kg	3.8					
安装方式 Installation method		任意Arbitrarily					
设计承重 Design load	kg	30					

*以上技术参数仅供参考, 实际根据客户提供的数据, 会出具相关的技术参数及尺寸。

* The above technical parameters are for reference only. According to the data provided by the customer, the relevant technical parameters and dimensions will be issued.

外形尺寸图表 Outline dimensional

HRZ130配57步进 HRZ130 with 57 stepping motor

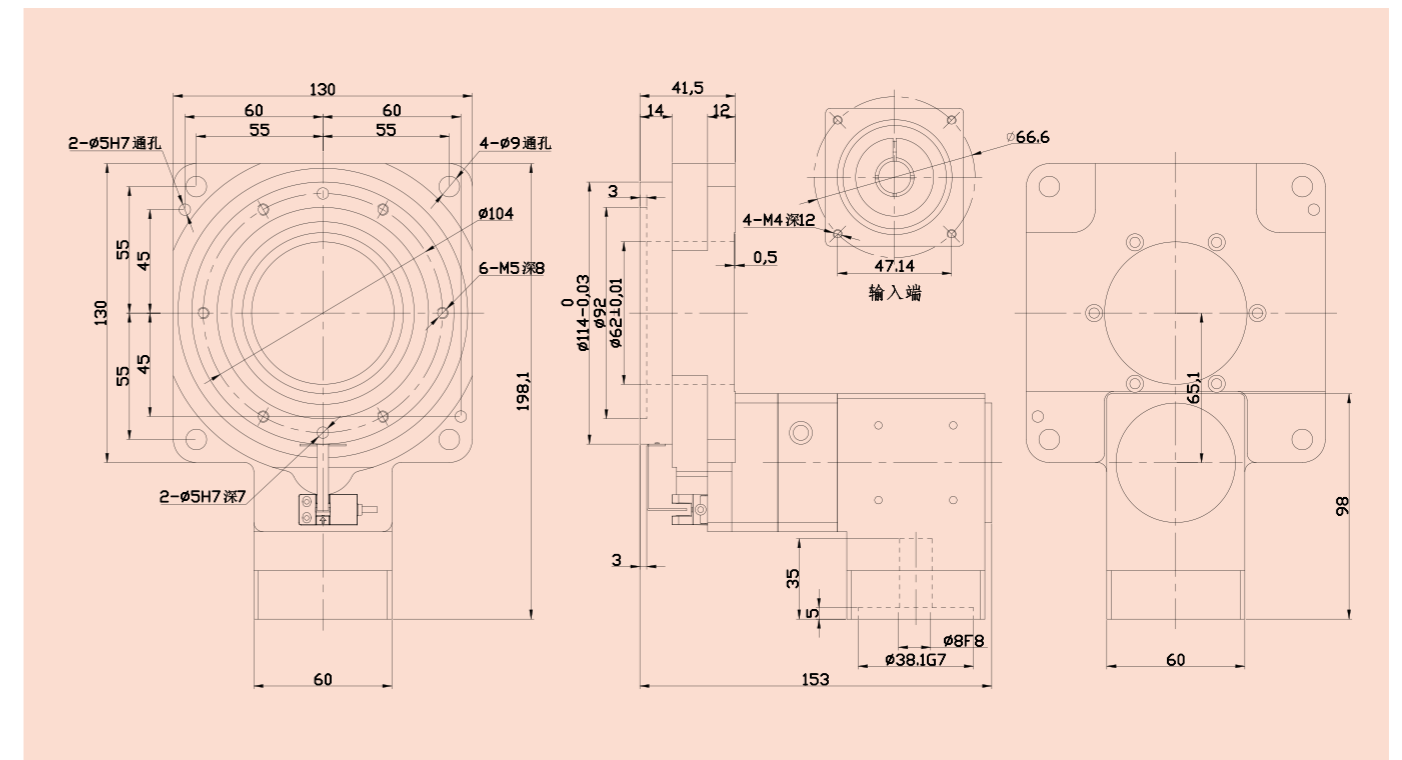

HRZ130配400W伺服 HRZ130 with 400W servo motor

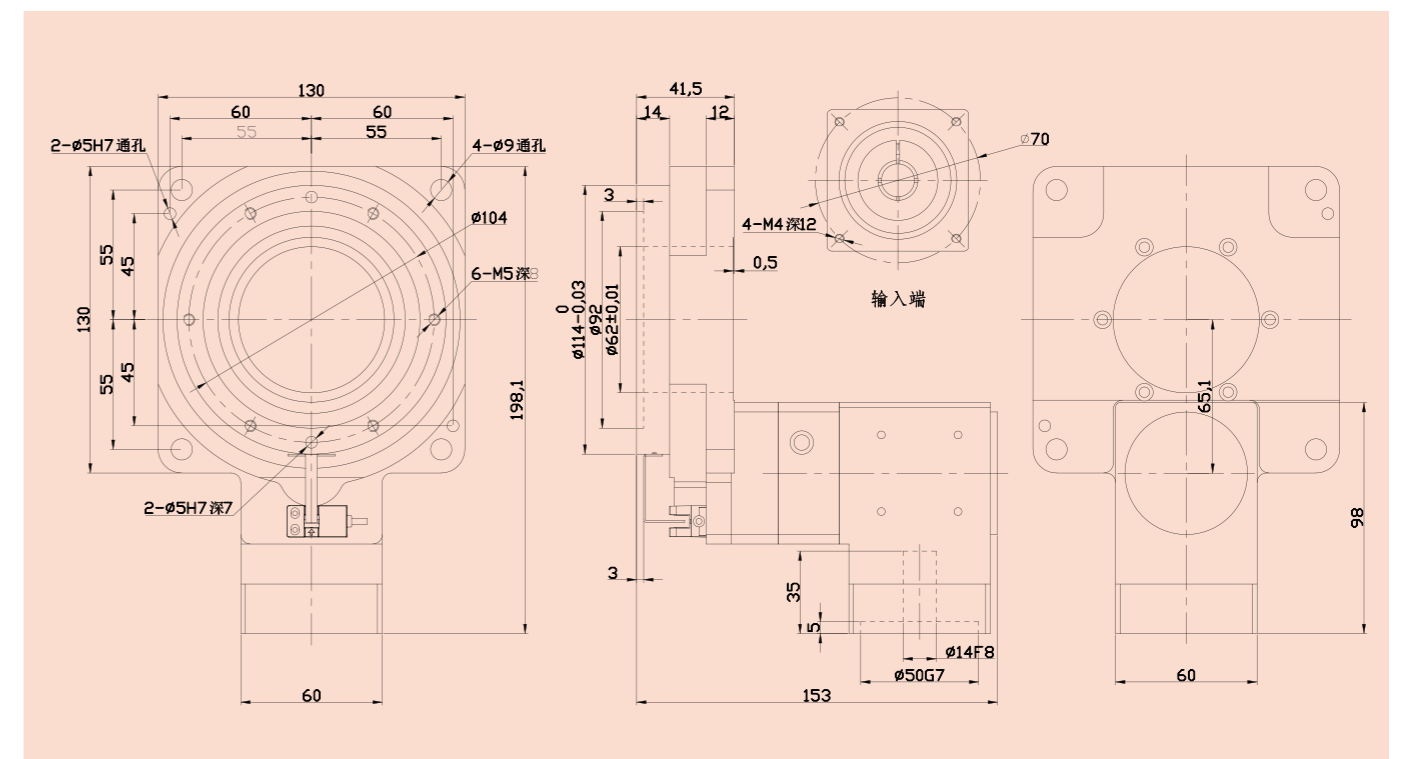

型号说明 MODEL ILLUMINATE

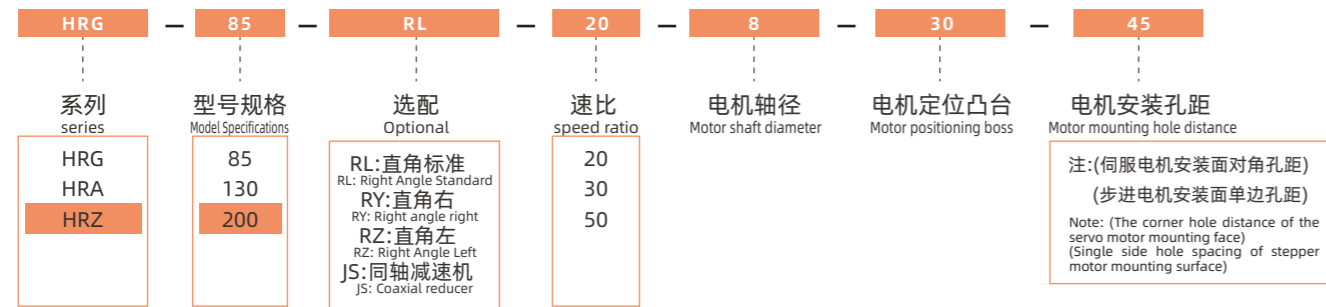

技术参数 TECHNICAL PARAMETER

型号 Model	单位 Unit	HRZ200配750W伺服				
减速比 Ratio		30	40	50	70	100
额定输出扭矩 Rated torque	N·m	70				
最大输出扭矩 Maximum torque		3倍额定输出扭矩 3 times rated torque				
轴承结构 Bearing		交叉滚子轴承 Cross roller bearing				
容许轴向负载 Allowable axial load	N	4000				
容许惯性力矩 Allowable inertia torquel	N·m	100				
容许盘面转速 Allowable output speed		200rpm(间歇运转 Indexing operation)				
旋转平台平行度 Outqut concentricity	mm	≤0.01				
旋转平台同心度 Overturning torque	mm	≤0.01				
齿隙 Backlash		无齿隙 (可调节) Zero backlash (adjustable)				
扭转刚性 Torsional rigidity	N·m/arcmin	32				
精度寿命 Aocuracy life		30000h(间歇运转 Indexing operation)				
定位精度 Positioning accuracy	arcmin	≤3				
反复定位精度 Repeatability	arcsec	≤30				
防护等级 Protection level		IP50				
适配电机接口 Adapter motor interface		750W伺服 (Ø19/Ø70-Ø90)				
光电开关 Sensor		标配 Free supply				
润滑方式 Lubrication method		长效润滑 Long term lubrication				
传动效率 Efficiency		90%				
噪音 Noise	dB	63				
重量 Weight	kg	12.2				
安装方式 Installation method		任意 Arbitrarily				
设计承重 Design load	kg	55				

*以上技术参数仅供参考，实际根据客户提供的数据，会出具相关的技术参数及尺寸。

* The above technical parameters are for reference only. According to the data provided by the customer, the relevant technical parameters and dimensions will be issued.

外形尺寸图表 Outline dimensional

HRZ200配750W伺服 HRZ200 with 750W servo motor

